

# Irrigation and Drainage Engineering

(Soil Water Regime Management)

(ENV-549, A.Y. 2025-26)

4ETCS, Master option

**Prof. Paolo Perona, Dr. Giulio Calvani**  
Platform of Hydraulic Constructions



Lecture 3.2. Surface irrigation:  
water conveyance, design of  
(linear) structures

# Longitudinal profile

Water velocity  $U$  must remain within well-defined limits

$U = f(\text{slope, type of profile, geometry})$

**Velocity too small**

- sediment deposit
- generate canal oversizing  $U_{\min} > 0.5 \text{ m/s}$
- increase the risk of waterborn diseases spreading (e.g., malaria)

**Velocity too high**

- erosion risk
- torrential flow regime
- water splashes outwards
- increase the risk of waterborn diseases spreading (e.g., onchocerciasis a.k.a. *river blindness*)

Maximal velocity:

- Earthen canals =  $f(\text{nature of profile materials and sediment load})$   $0.5 < U_{\max} < 1 \text{ m/s}$
- Concrete canals  $U_{\max} < 2 \text{ m/s}$

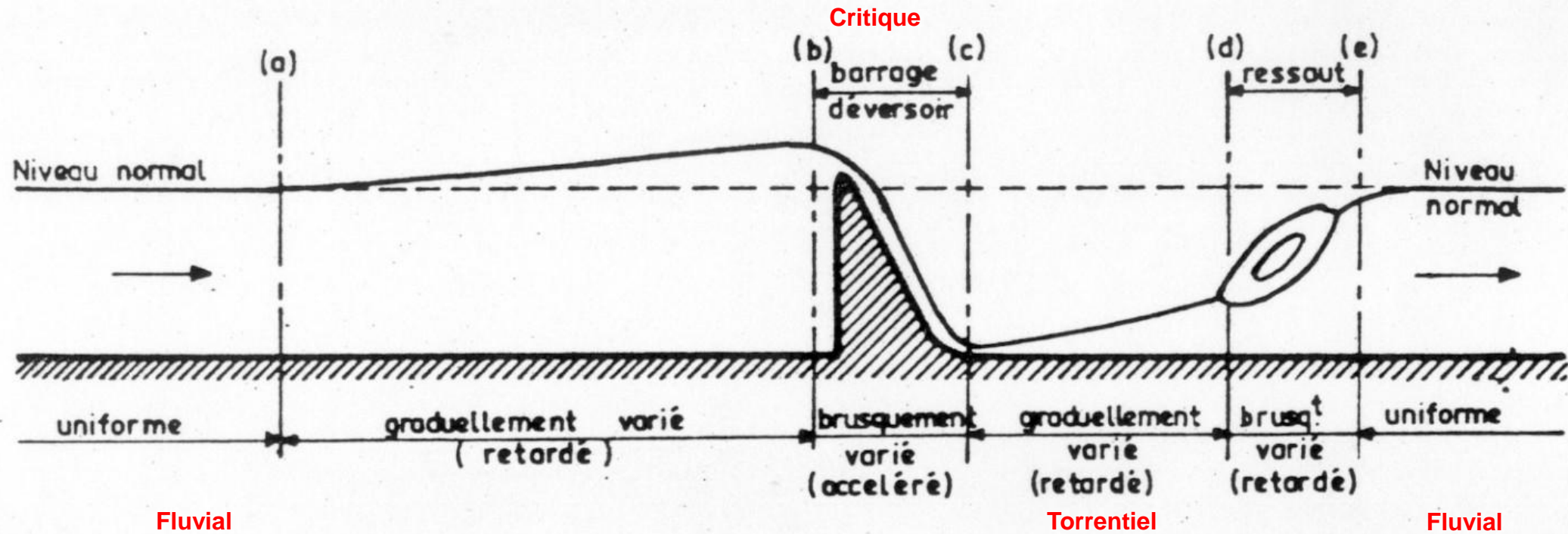

Steady-state flow at a spillway dam, in a homogeneous channel with a gentle slope

# Design (sizing) of a canal

Channel sizing frequently based on the assumption of **uniform flow**

## Hypotheses

Flow conditions do not vary from one section to the next, so the channel must be long and homogeneous (straight section, constant slope and roughness).

## Properties

- the load line is parallel to the free surface and the bottom of the channel (invert)
- the slope of the load line  $S$  is equal to the slope  $S_f$  of the invert
- the head loss  $\Delta H$  over a channel length  $L$  is  $\Delta H = L S = L S_f$

## Sizing

Empirical formulas: Manning-Strickler, Chézy, etc. (all valid in the rough turbulent flow regime)

## Precision

Relatively low. It depends on the appropriateness of the roughness coefficient used and the plausibility of the assumptions.

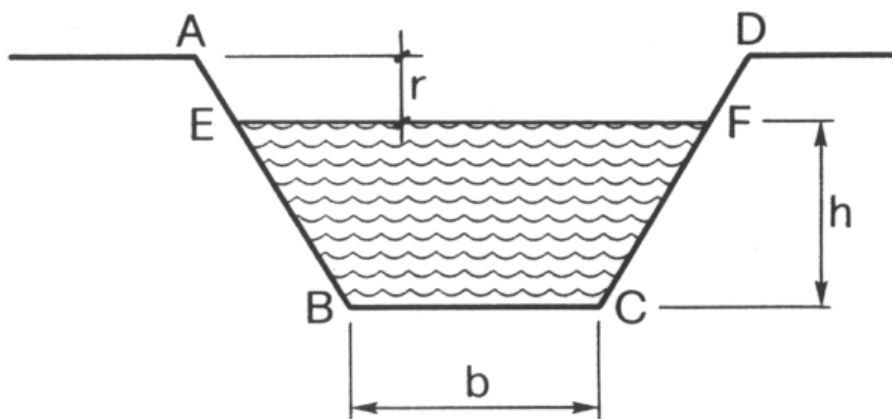

Manning-Strickler formula:

$$Q = k A R^{2/3} S^{1/2}$$

$k$  : roughness coefficient ( $m^{1/3}/s$ )

10 <  $k$  < 100

Ditch in poor condition,  
overgrown with vegetation

Smooth cement walls in  
perfect condition

At the pre-project stage, we frequently adopt

- Concrete channels :  $60 < k < 70 [m^{1/3}/s]$
- Earthen canals :  $30 < k < 40 [m^{1/3}/s]$

Value of the Manning-

Strickler roughness

coefficient  $k$  ( $m^{1/3} s^{-1}$ ) for

some common material

and applications

$k$  is sometimes called Gauckler-Strickler coefficient

$n$  is the Manning coefficient

$$k = n^{-1}$$

Nature des “parois mouillées”	État des parois			
	Parfait	Bon	Assez bon	Mauvais
<b>Tuyaux:</b>				
en fonte, sans enduit	83	77	71	67
en fonte, avec enduit	91	83 *	77	-
en acier	77	67 *	59	-
<b>Canaux revêtus:</b>				
Parois en ciment lissé	100	91	83	77
Canaux revêtus de béton	83	71 *	63	56
Moellons bruts cimentés	59	50	40	33
Pierres sèches	40	33	30	29
<b>Canaux et fossés non revêtus:</b>				
en terre, rectilignes et uniformes	59	50	44 *	40
en terre, à larges méandres	44	40 *	36	33
à fond en terre, berges en galets	36	33	30 *	27
<b>Cours d'eau naturels:</b>				
Berges propres et rectilignes	40	36	33	30
Berges propres et rectilignes mais avec quelques herbes et pierres	33	30	29	25
Canaux naturels avec méandres et endroits peu profonds	30	29	25	22
Zones avec beaucoup de végétation	13	10	8	7

# Water conveyance structures for gravity irrigation

## Example of water conveyance facilities



Main canal



Tertiary canal

Leveling works to ensure proper water distribution

Sometimes pumps and pressure flow to irrigate areas at higher elevation

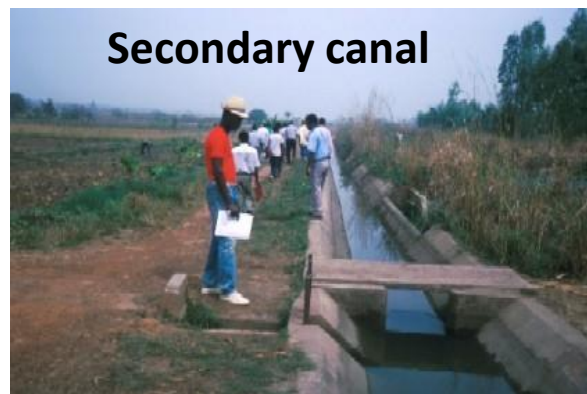

Secondary canal



Distribution channel (ditch)

# Water conveyance structures for gravity irrigation

## Example of water conveyance facilities

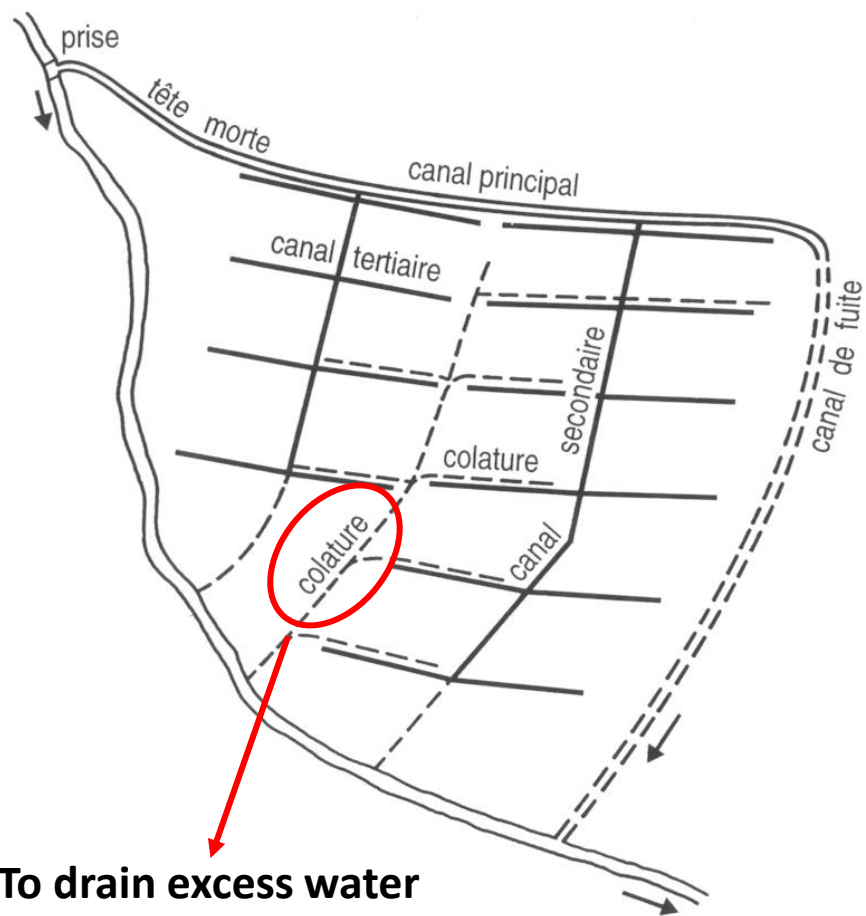

## Traffic lanes along a canal

- access to plots
- maintenance and monitoring of canals and structures



Protection dikes

## Point structures

- Regulation (gates, valves)
- Distribution (dividers, gates)
- Safety (siphons, draining devices) to prevent overflows

# Soil foundation characteristics

## Canals without revetment (earthen channels)

- Hydraulic conductivity (losses due to infiltration)
- Soil cohesion (bank slope stabilization)

✓ Soils with wide range of granulometry

## Canals with revetment (lined channels)

TO AVOID (IF POSSIBLE)	SOLUTION (IF IMPOSSIBLE)
Light density soil	<ul style="list-style-type: none"><li>• Strong compaction</li></ul>
High clay content	<ul style="list-style-type: none"><li>• replace the layer</li><li>• stabilise the surface</li><li>• use a flexible coating</li></ul>
Unstable zones	<ul style="list-style-type: none"><li>• Complete sealing of the canal</li></ul>
Soils with high salinity content	<ul style="list-style-type: none"><li>• High-density concrete and special cements</li><li>• Aboveground structures (aqueducts)</li></ul>



# Attack of concrete by soluble substances

Most salts pose a threat to concrete in high concentrations, but particularly sulphates, especially Mg sulphates.

In the presence of salts, very dense concrete and special cements\* (low in lime) must be used.

**Note:** steel is also corroded by sulphates

**\*Pozzolanic cement:** cement containing natural pozzolans (volcanic slag: small particles of pumice) or siliceous fly ash (very fine powdery products from the dusting of combustion gases from thermal power stations).



The porosity of concrete encourages the penetration of salts into the structure, which can dissolve certain minerals in the concrete.

# Plan layout of canals

In hilly terrain, the layout of canals and colatures is dictated by the topography.

In regular terrains, the optimum solution is function of:

- ✓ Maximal surface of the districts
- ✓ Admissible length of the plots
- ✓ Plots layout and distribution
- ✓ Soil characteristics
- ✓ Financial aspects, etc.

## Main canal :

- ✓ generally sized for peak flow conditions
- ✓ usually placed in a dominant position with a gentle slope
- ✓ where possible, a balance of cut and fill to regularize
- ✓ gradual change of direction for large channels

## Secondary channels:

- ✓ generally placed on ridge lines
- ✓ often laid on the surface or above the ground
- ✓ sized to carry several handling flows
- ✓ if necessary (slope too steep), waterfalls

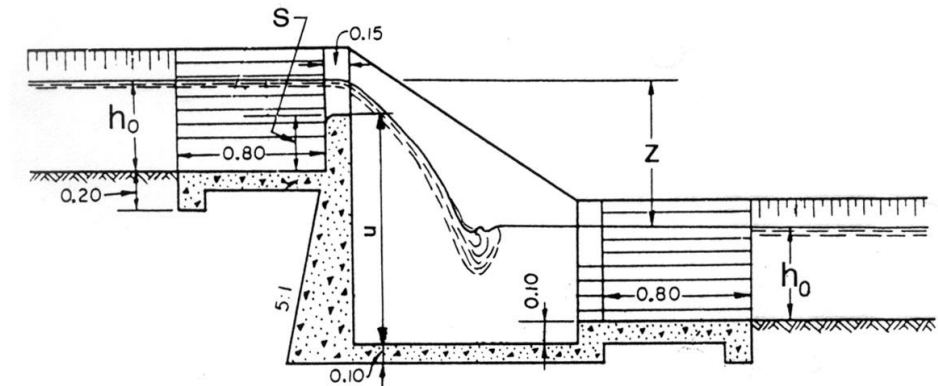

Distribution channels

Waterfall structure

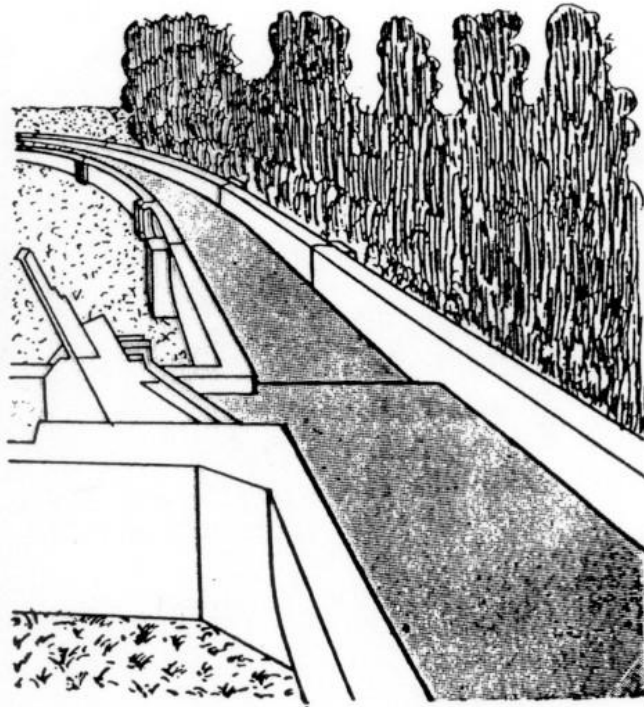

**Secondary channels laid on the ground  
and supported channels**

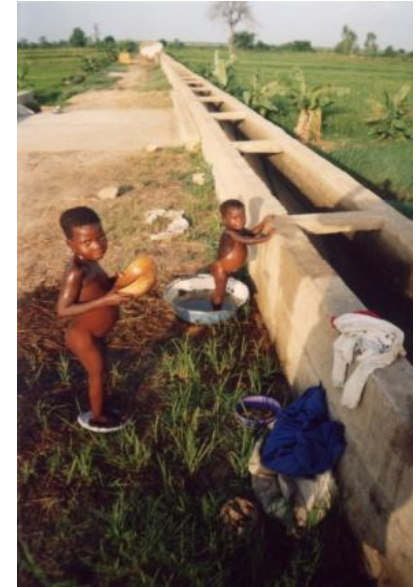

# Cross-section profiles

## Trapezoidal profile

- earthen canals
- small canals lined on site
- large canals

## Other profiles

- transport of small flows
- crossing obstacles



profil trapézoïdal



profil rectangulaire

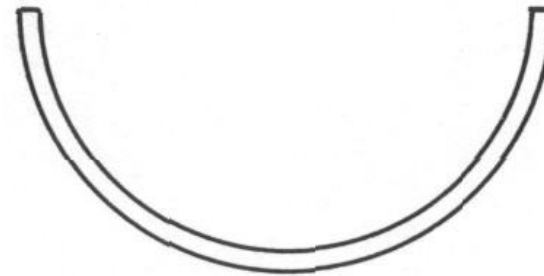

profil semi-circulaire

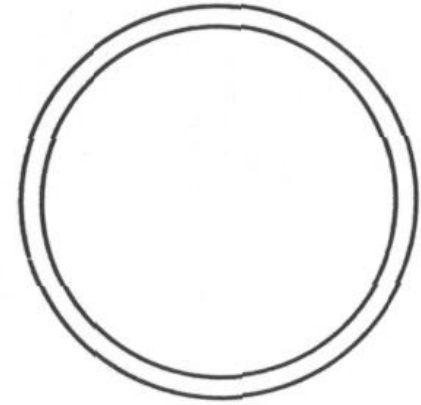

profil circulaire

**Main cross-section profiles of irrigation canals**

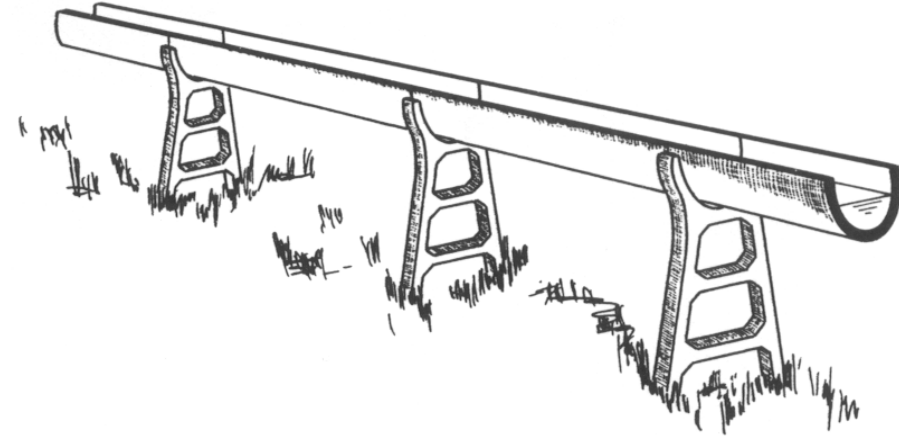
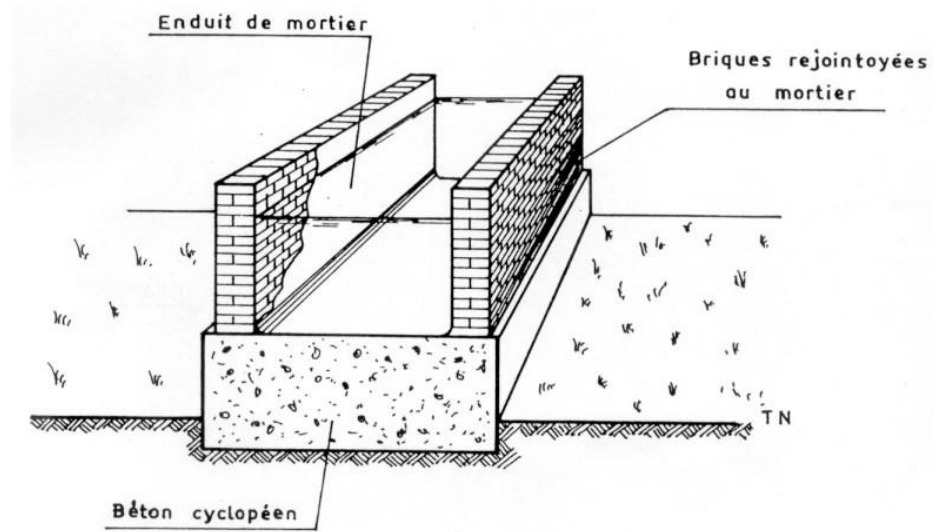

Rectangular profile



Circular Profile



Semi-circular profile

## Prefabricated channels

- Variable cross-section (rectangular, circular, semi-circular, semi-oval, triangular, etc.)
- supplied in prefabricated units 5 to 7 m long
- usually in pre-stressed reinforced concrete, but also in steel, plastic, etc.

## Ported channels

Channels placed on supports (max. height: 2 to 3 m)

### Advantages

- channels can be sloped, even on flat ground
- small, easily negotiated topographical obstacles
- dominant position of the water
- small footprint
- easy to detect leaks

### Disadvantages

- cost
- delicate installation, fragile elements
- crossing traffic lanes

